

OCR

Oxford Cambridge and RSA

H

Wednesday 22 May 2019 – Afternoon

GCSE (9–1) Physics B (Twenty First Century Science)

J259/03 Breadth in physics (Higher Tier)

Time allowed: 1 hour 45 minutes

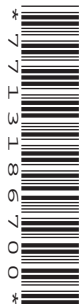

You must have:

- a ruler (cm/mm)
- the Data Sheet for GCSE Physics B (inserted)

You may use:

- a scientific or graphical calculator
- an HB pencil



Please write clearly in black ink. **Do not write in the barcodes.**

Centre number

--	--	--	--	--

Candidate number

--	--	--	--

First name(s)

Last name

INSTRUCTIONS

- The Data Sheet will be found inside this document.
- Use black ink. You may use an HB pencil for graphs and diagrams.
- Answer **all** the questions.
- Where appropriate, your answers should be supported with working. Marks may be given for a correct method even if the answer is incorrect.
- Write your answer to each question in the space provided. If additional space is required you should use the lined page(s) at the end of this booklet. The question number(s) must be clearly shown.

INFORMATION

- The total mark for this paper is **90**.
- The marks for each question are shown in brackets [].
- This document consists of **28** pages.

2

Answer **all** the questions.

1 Amir investigates melting ice.

He puts ice cubes on different materials. He then measures the time taken for each ice cube to completely melt.

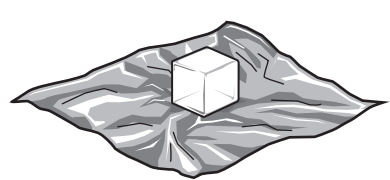

Metal foil

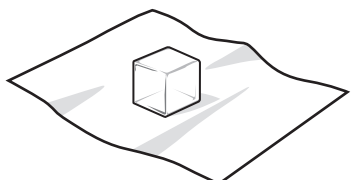

Paper

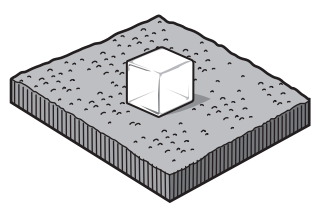

Carpet

Amir's results are shown in the table.

Material	Time (min)
Metal foil	86
Paper	105
Carpet	162

(a) Calculate the thermal energy needed to melt 20g of ice.

The specific latent heat of melting for ice is 334 000 J/kg.

Thermal energy =J [3]

(b) Explain why the ice cubes take different times to melt on different materials.

.....

.....

.....

.....

.....

..... [2]

3

(c) Amir discusses the experiment with Nina, another student.

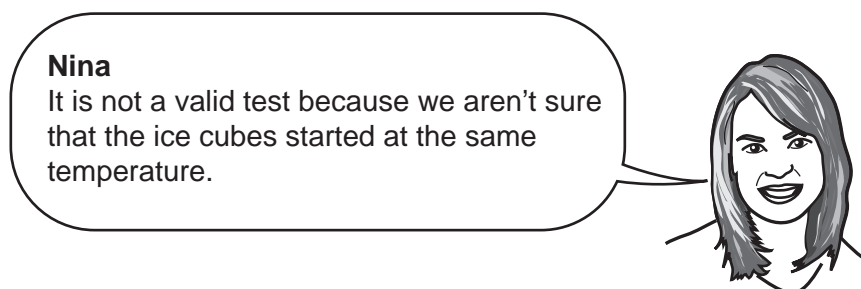
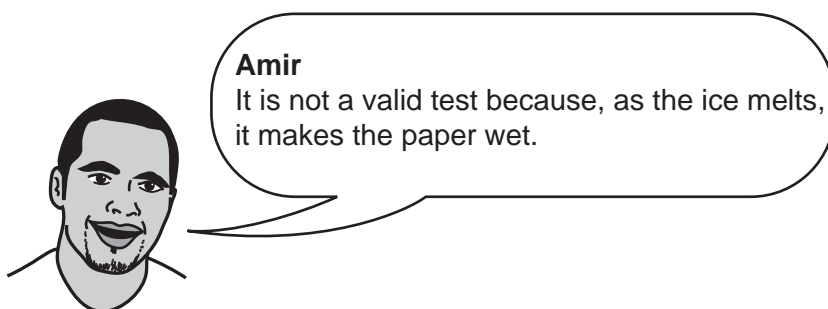

(i) Suggest improvements to the experiment to solve each of these problems.

Amir's problem

.....
.....

Nina's problem

.....
..... [2]

(ii) Amir wants to speed up the experiment so it can be repeated more quickly.

Suggest **one** way he can change the experiment so that the ice melts more quickly, without making the experiment invalid.

.....
..... [1]

2 Jamal is on a water slide.

(a) Fig. 2.1 shows the force of gravity (weight) acting on Jamal.

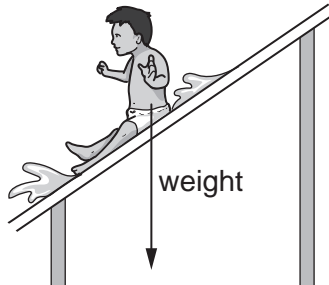

Fig. 2.1

(i) Add an arrow to Fig. 2.1 to show the normal contact force between Jamal and the slide. Label this arrow **N**. [1]

(ii) Add an arrow to Fig. 2.1 to show the force of friction between Jamal and the slide. Label this arrow **F**. [1]

(b) (i) State Newton's third law.

.....

.....

..... [2]

(ii) Explain how Newton's third law applies to the force of gravity (weight) acting on Jamal.

.....

..... [1]

3 Beth works at a nuclear power station.

She is asked to investigate the risk caused by radioactive isotopes accidentally coming into contact with food.

(a) Would swallowing this food be a contamination effect or an irradiation effect?

Contamination effect

Irradiation effect

Explain your answer.

.....
 [2]

(b) Explain why it is hazardous if radioactive isotopes enter the body.

.....

 [1]

(c) Information about three isotopes is shown in the table.

Isotope	Type of decay	Half-life	Biological effects
Plutonium-241	beta	14 years	absorbed by the bones
Radium-226	alpha	1600 years	absorbed by the bones
Technetium-99m	gamma	6 hours	excreted after a few days

Which isotope is most hazardous when inside the body?

Explain your answer.

.....

 [2]

6

- 4 Kareem investigates the behaviour of a spring when it is loaded with masses and then unloaded.

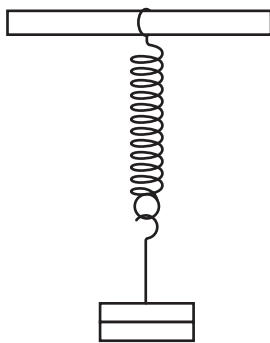

He measures the extension of the spring each time he changes the load and plots his data onto the graph shown below.

Key	
x	loading
+	unloading

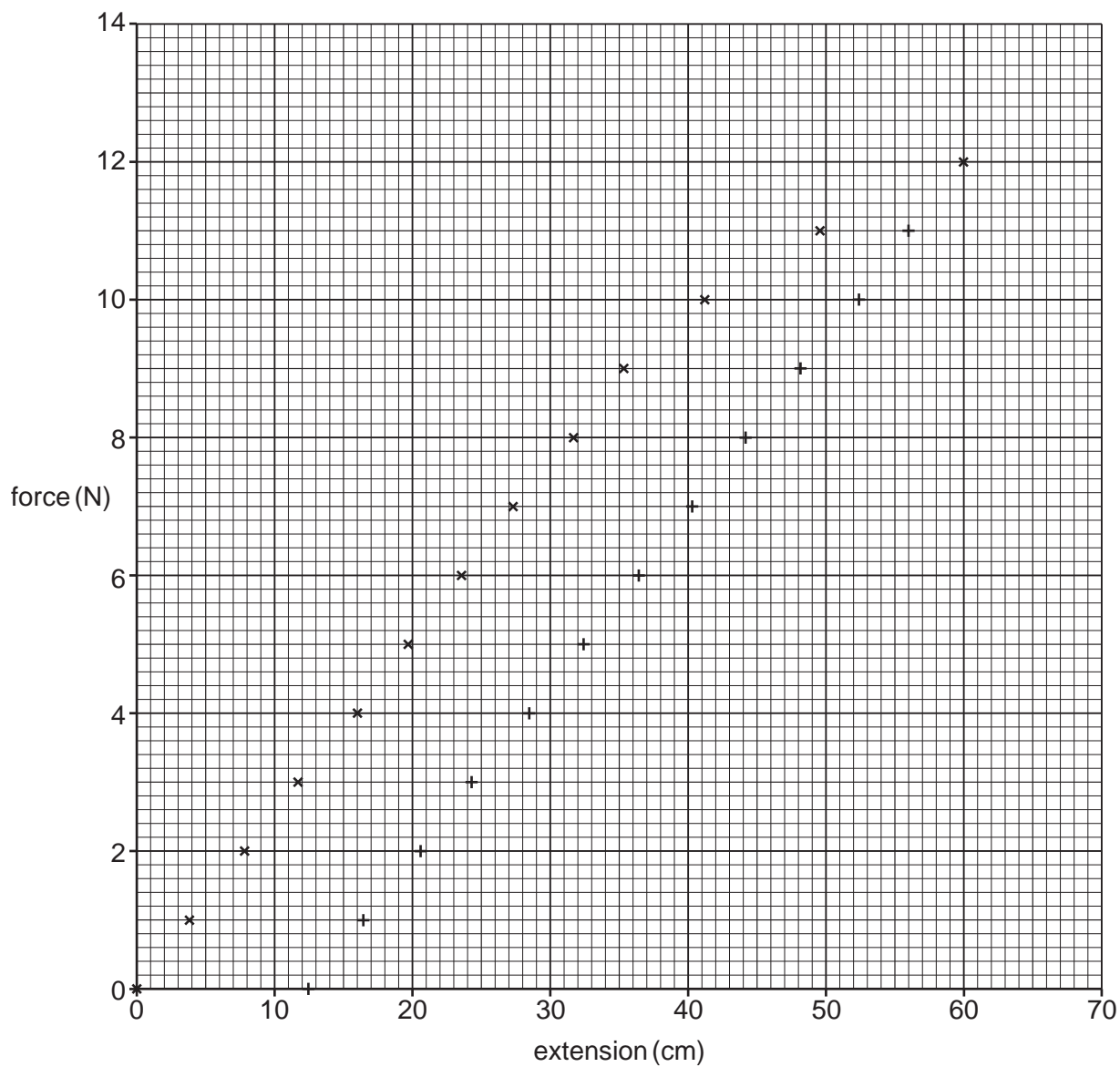

Kareem

The spring is non-linear above 8 N and it shows plastic deformation. I can't use this type of spring as a device to measure forces.



(a) (i) Explain how the data from the graph shows that the spring is non-linear.

.....
.....
.....
..... [2]

(ii) Suggest whether a non-linear spring could be used as a device to measure forces.

Justify your answer.

.....
..... [1]

(b) (i) Explain how the data on the graph shows plastic deformation.

.....
..... [1]

(ii) Eve also looks at the data shown on the graph.

Eve

The spring might only show plastic deformation for larger forces.



Suggest how to find out the force at which plastic deformation begins for this type of spring.

.....
.....
.....
..... [2]

8

(c) Kareem uses his spring to measure the weight of a metal block as 5.1 N.

Calculate the mass of the metal block.

Use the equation: weight = mass \times gravitational field strength

Gravitational field strength = 10 N/kg

Mass =kg [2]

5 Thorium-232 is radioactive. It decays to an isotope of radium.

The graph in **Fig. 5.1** shows how the number of neutrons and protons in the nucleus changes during this decay.

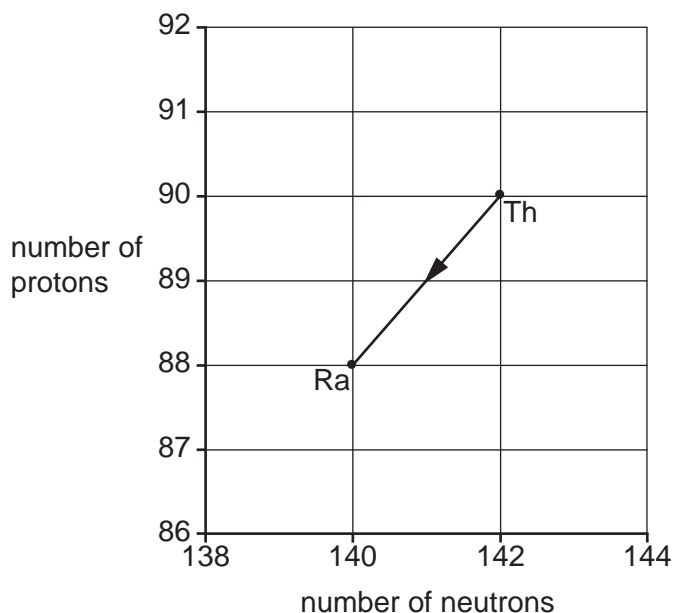
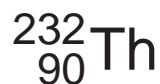

Fig. 5.1

(a) Thorium-232 can be represented as:



Complete the correct representation of the isotope of radium shown in **Fig. 5.1**.



[2]

(b) State the type of radiation emitted during the decay shown in **Fig. 5.1**.

Give a reason for your answer.

Type of radiation

Reason

..... [2]

(c) The isotope of radium is also radioactive. It decays by emitting a beta particle.

Add an arrow to the graph in **Fig. 5.1** to show this decay.

[1]

10

- 6 Kai is designing a head torch. The torch uses three small lamps.

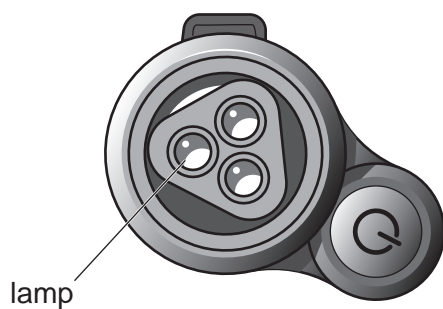

The series circuit for Kai's first design is shown in **Circuit A**.

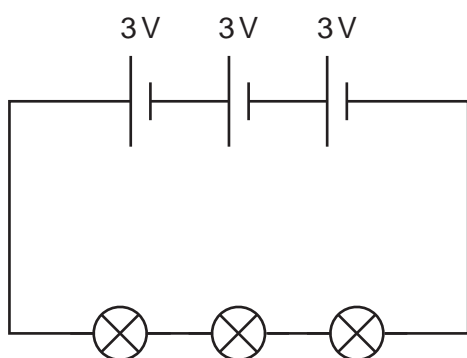

Circuit A

- (a) The resistance of each bulb is $2800\ \Omega$.

Calculate the current in **Circuit A**.

Give your answer to **2** significant figures.

Current = A [4]

- (b) Kai changes the circuit so that it now contains only one cell, but with the lamps wired together in parallel, as shown in **Circuit B**.

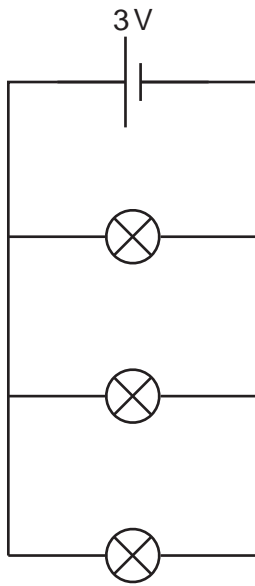

Circuit B

- (i) Describe and explain how the brightness of the lamps in **Circuit A** compares to the brightness of the lamps in **Circuit B**.

.....

 [2]

- (ii) Justify which circuit is most suitable for use in the torch.

.....

 [1]

7 Sarah experiments with magnets.

- (a) (i) Complete the diagram by drawing the pattern of magnetic field lines around the bar magnet.

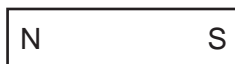

[2]

- (ii) Describe where the magnetic field is strongest, and how this is shown by the field lines.

.....
.....
..... [1]

- (b) Sarah makes a needle for a compass.

She repeatedly moves the needle across the bar magnet until it is magnetised. She then suspends the needle from a thread and it points north.

Explain whether the compass needle is a permanent or induced magnet.

.....
.....
.....
..... [2]

13
BLANK PAGE

PLEASE DO NOT WRITE ON THIS PAGE

14

8 A solar flare is an explosion on the surface of the Sun.

Solar flares release huge amounts of radiation, including visible light and X-rays.

(a) Describe **two** differences between visible light and X-rays.

- 1
-
- 2
- [2]

(b) Sometimes when there is a solar flare, a huge cloud of gas is also forced out from the Sun.

Jack finds out the following information:

- Speed of X-rays in a vacuum 3.0×10^8 m/s
- Typical wavelength of X-rays: 0.10 nm
- Time taken for visible light to travel from the Sun to the Earth: 8.3 minutes
- Speed of cloud of gas: 500 000 m/s

(i) Use the data to calculate the typical frequency of X-rays.

Frequency = Hz [3]

15

- (ii) Calculate the time taken, in minutes, for the cloud of gas to reach the Earth.

Time taken =minutes [4]

- 9 Jane investigates the maximum power provided by two types of solar cell, as shown in **Fig. 9.1**. The solar cells are **not** the same size.

Cell X

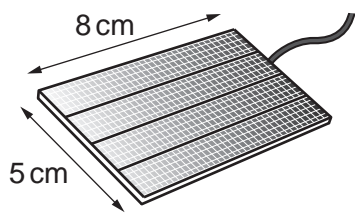

Cell Y

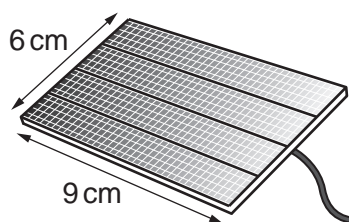

not to scale

Fig. 9.1

Jane uses the circuit shown in **Fig. 9.2** to measure the power provided by each cell. She carefully controls the intensity of light falling on each solar cell so that it does not change.

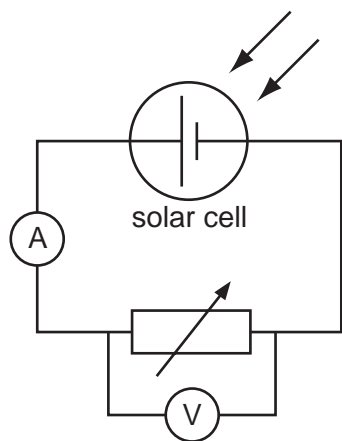

Fig. 9.2

- (a) Describe how to use the circuit in **Fig. 9.2** to measure the maximum power provided by each cell.

Include details of any calculations that must be completed.

.....

.....

.....

.....

.....

.....

.....

.....

[3]

(b) The table shows the results of Jane's experiment.

Cell	Maximum power (W)
X	25
Y	32

Ben
Cell X is the most effective because it has the greatest maximum power.



Jane
It is not a fair comparison because the cells X and Y are not the same size.



Compare the effectiveness of solar cells X and Y, taking into account their surface area.

.....

.....

.....

.....

.....

.....

..... [3]

(c) Suggest **two** factors, other than maximum power, that could affect someone's decision to use solar cells to generate electricity for their home.

1

.....

2

.....

[2]

10 Amaya and Li are clowns in a circus. They are preparing a new show.

In the show, a water balloon will be dropped on Li's head from different heights. Amaya lifts the water balloon to a height 5.0 m above Li's head using a pulley.

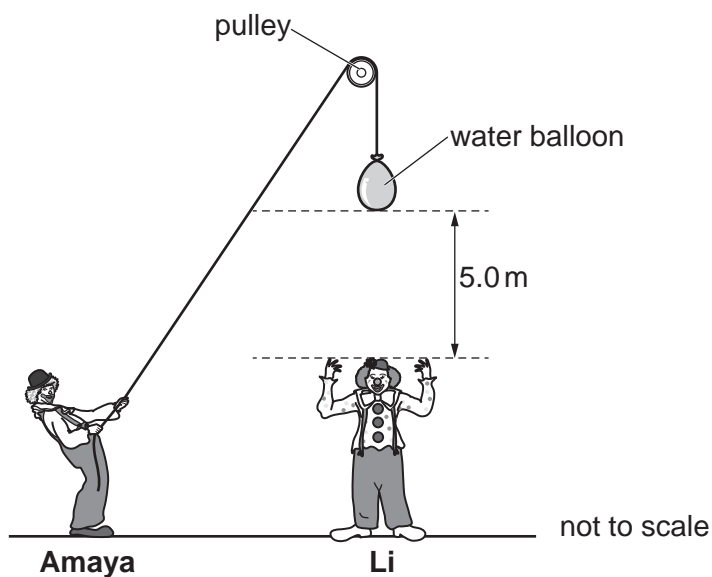

(a) Describe all the **changes** in the way energy is stored, starting from before Amaya starts to lift the water balloon, and finishing after the water balloon has hit Li.

In your answer you should clearly state what is happening to the water balloon as the energy is transferred between each of the stores.

.....

.....

.....

.....

.....

.....

.....

.....

.....

..... [3]

19

(b) The mass of the water balloon is 1.6 kg.

- (i) Calculate the minimum work that must be done by Amaya to lift the water balloon a height of 5.0 m.

Gravitational field strength = 10 N/kg

Work done =J [2]

- (ii) Use your answer to (b)(i) to calculate the maximum possible speed of the water balloon when it hits Li.

Speed =m/s [3]

11 Kepler-445d is a planet orbiting a distant star in our galaxy. It was discovered in 2015.

Astronomers believe that Kepler-445d is similar to the Earth. However, it orbits a star that emits light with a longer principal wavelength than the Sun.

(a) State how the surface temperature of the star compares to the surface temperature of the Sun.

.....
..... [1]

(b) The intensity of radiation emitted by the star is much lower than that emitted by the Sun. However, the surface temperature of Kepler-445d is thought to be similar to the surface temperature of the Earth.

Give **two** possible reasons to explain how Kepler-445d could be at a similar temperature to Earth.

1
.....
2
..... [2]

(c) James and Mia discuss whether scientists should look for life on Kepler-445d.



James
The government should spend money on new, bigger telescopes to search for life on Kepler-445d.

Mia
We will never know if there is life on Kepler-445d. Searching for life is a waste of money.



Who do you agree with? Explain why.

James

Mia

Explanation

.....

.....

.....

..... [2]

12 Sundip reads an article about a new way to generate electricity.

Scientists have invented 'energy harvesters' called 'twistrans'. Twistrans are made by twisting carbon fibres.

When a twistran changes shape, it can generate electricity. 1 kg of twistrans could generate up to 250W of electrical power. The efficiency of a twistran is only 1.1%.

In the future, twistrans could be sewn into people's clothes so that they generate electricity as they move around.

(a) (i) Calculate the possible energy transferred from 3.5×10^{-5} kg of twistrans in 1 minute.

Energy output =J [3]

(ii) Calculate the total power supplied for a twistran to transfer a useful output power of 10W.

Give your answer to 2 significant figures.

Total power = W [3]

(b) (i) Describe a positive impact that twistrans and other similar inventions could have on society.

.....
.....
..... [1]

(ii) Suggest why the scientists decided to give their invention of 'twistran' a short and memorable name.

.....
.....
..... [1]

13 Alex is a deep-sea diver.

As he swims downwards into the ocean, the pressure changes.

(a) Explain why the pressure changes with increasing depth in the ocean.

.....

.....

.....

..... [2]

(b) The graph shows how pressure changes with depth of seawater.

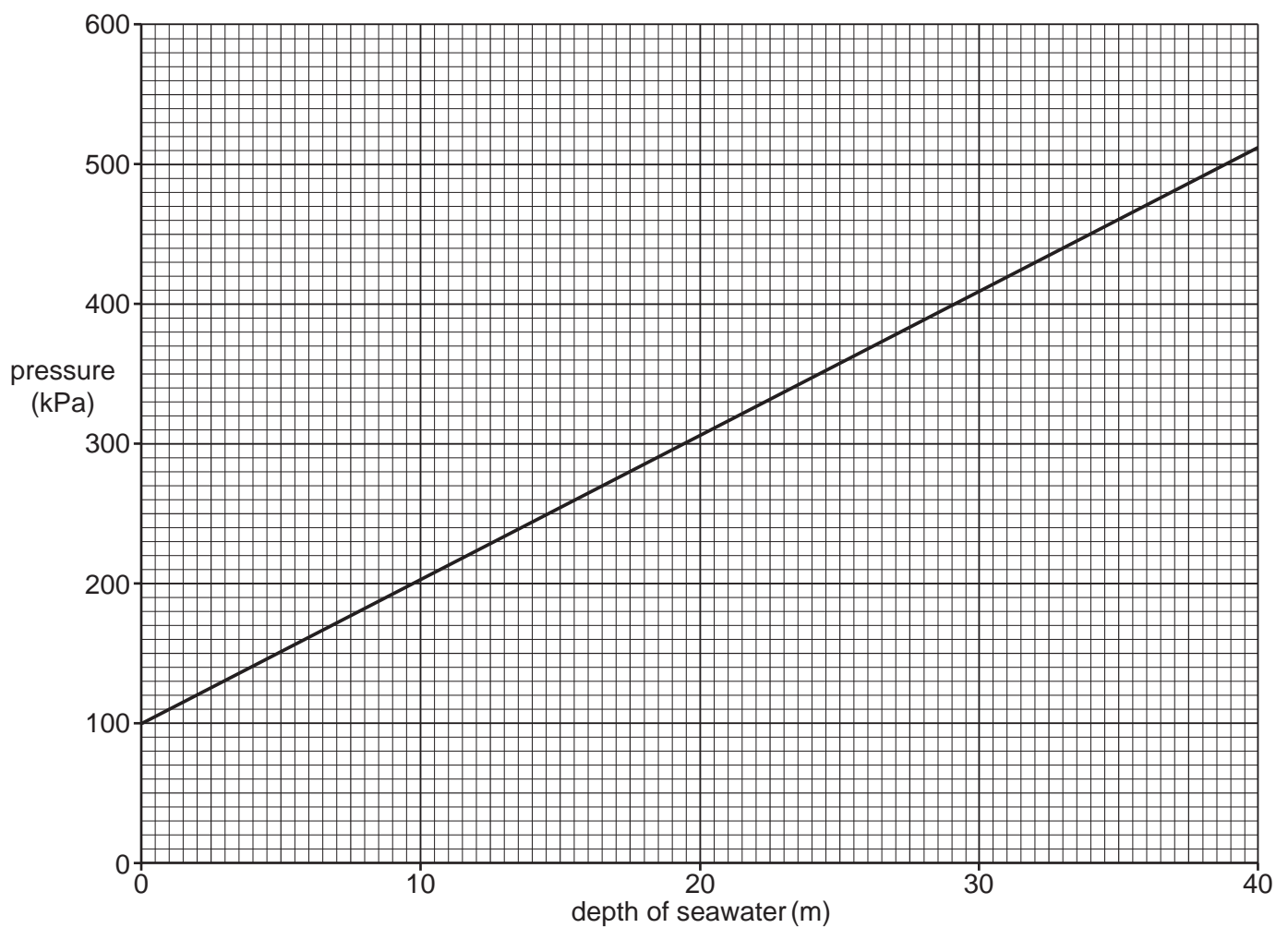

25

- (i) Determine the intercept of the graph.

Intercept = kPa [1]

- (ii) Explain the physical meaning of the value of the intercept.

.....
.....
.....
..... [2]

- (c) (i) Determine the gradient of the graph.

Gradient = kPa/m [2]

- (ii) Calculate the density of seawater.

Use the equation: density = gradient of graph \div gravitational field strength

Gravitational field strength = 10 N/kg

Density = kg/m³ [2]

END OF QUESTION PAPER

ADDITIONAL ANSWER SPACE

If additional space is required, you should use the following lined page(s). The question number(s) must be clearly shown in the margin(s).

A large area of lined paper for writing. It features a vertical solid line on the left side, creating a margin. The rest of the page is filled with horizontal dotted lines, providing space for writing answers.

A grid of 20 columns and 30 rows of dotted lines for writing. The grid is formed by a solid vertical line on the left and horizontal dotted lines. The first column is narrow, while the remaining 19 columns are wider and of equal width.

A large area of the page is reserved for writing, featuring a vertical solid line on the left side and horizontal dotted lines extending across the page.



Copyright Information

OCR is committed to seeking permission to reproduce all third-party content that it uses in its assessment materials. OCR has attempted to identify and contact all copyright holders whose work is used in this paper. To avoid the issue of disclosure of answer-related information to candidates, all copyright acknowledgements are reproduced in the OCR Copyright Acknowledgements Booklet. This is produced for each series of examinations and is freely available to download from our public website (www.ocr.org.uk) after the live examination series.

If OCR has unwittingly failed to correctly acknowledge or clear any third-party content in this assessment material, OCR will be happy to correct its mistake at the earliest possible opportunity.

For queries or further information please contact The OCR Copyright Team, The Triangle Building, Shaftesbury Road, Cambridge CB2 8EA.

OCR is part of the Cambridge Assessment Group; Cambridge Assessment is the brand name of University of Cambridge Local Examinations Syndicate (UCLES), which is itself a department of the University of Cambridge.